



Off-line cooler BNK ATEX-3GD

Drives and hydraulic aggregates are also used in explosive areas in machine construction or raw material production.

In hydraulic systems oil transfers power and motion, in drives it's a vital lubricant. Both as a power transfer medium and lubricant oil is heated by friction losses during operation. Oil/air coolers stabilise the temperature and are indispensable for systems and drives for consistent power. The temperature further affects the ageing behaviour and the life of oils.

BNK ATEX 3GD series coolers are suitable for use in zones 2 (gas) and 22 (dust) and temperature class 3. In addition to adequately protected drive motors they are designed for easy maintenance and have a noise-optimised fan.

To minimise the negative fluctuating oil flow has on the cooler design with varying ambient air temperatures, the BNK ATEX series features a built-in gerotor pump to circulate the oil.

ATEX area of application: up to zone 2 and zone 22 T3

Easy to maintain design

System-compatible cooling matrix / flow rate ratio

Low noise emission

Rugged cooling matrix

High suction pump

Compact installation dimensions



Introduction and description

Why coolers?

In many cases, installing an off-line cooler is not only an emergency solution, but also the best solution with respect to mechanics and economics. Oftentimes off-line filtration can also be incorporated quite effectively.

Since a bypass also always requires installation of a separate circulation pump, it's reasonable to combine it with the motor already installed for the fan.

The BNK series is a tiered line of oil/air coolers with circulation pump directly flange-mounted. The cooler size and pump flow rate are coordinated for performance grades compatible with the system. The gerotor pump ensures low noise emission for the entire aggregate.

Why Bühler?

When we developed the BNK series, we incorporated our years of experience in designing and selling oil/air coolers. Especially the fatigue life of the cooling matrix was a focus during development.

The cooling matrix can easily be removed from the fan case for maintenance without uninstalling the fan or motor.

If our comprehensive standard range of products does not include the right solution for your application, we will gladly develop a custom solution for you.

Use the data in this leaflet to determine a suitable cooler for your application.

Construction and application

The BNK consists of the following components:

- Cooling matrix
- Fan case with mounting rails
- Blower and pump unit consisting of AC motor, pump, fan, protective/mounting grate and motor bracket

The cooling matrix and fan/pump unit can be removed from the fan case individually without having to uninstall other components

The BNK series cooling matrix are made from aluminum. The coolers are designed for use in hydraulic circuits.

We also offer cooling matrix bypass versions (see type code).

ATEX mark

ATEX marking on standard equipment

The ATEX mark depends on the version of the equipment and provides information on equipment category, equipment group, ex-atmosphere, ignition protection type. Please refer to the chart below for possible and complete markings.

Version for	Marking	Explanation
Gas	II 3G Ex h IIC T3 Gc	Zone 2 (IIC hydrogen only) Temperature class T3
Dust	II 3D Ex h IIIB T150 °C Dc	Zone 22 max. surface temperature 150 °C

Gas and dust atmosphere must not be present at the same time.

Ignition protection mark explanation

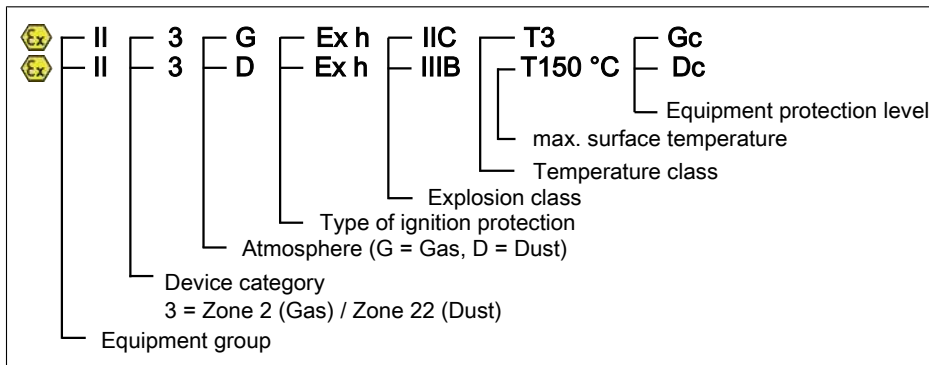

Model key

BNK 4.4-30-0.75kW-ATEX-3GDT3-IBx

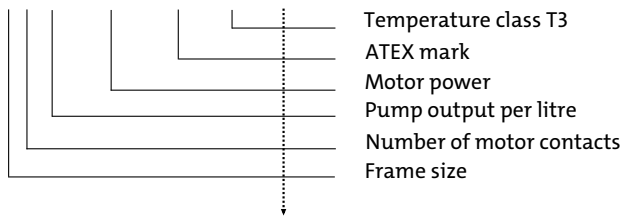

BNK 4.4-30-0.75kW-ATEX-3GDT3-IBx

If a bypass is desired, the information is added to the to the type designation:

Bypass version	AB	(BNK 2-7)	external bypass
	IBx	(BNK 3-7)	internal bypass
	ITB	(BNK 3-7)	internal temperature-dependent bypass 2 bar / 45 °C
	ATB	(BNK 2-7)	external temperature-dependent bypass 2 bar / 45 °C
	x		bypass value 2 bar, 5 bar, 8 bar

Technical data

Technical Data

Cooling battery:	Aluminium, RAL 7001, painted
Ventilation box, safety guard and motor brackets:	Stainless steel 1.4401, unpainted
Fan hub:	Aluminium die casting
Motor housing:	Aluminium die casting
Motor flanges:	Grey cast iron
Pump:	Anodised and impregnated aluminium, sintered steel
Operating fluids:	Mineral oils per DIN 51524 Gear oil per DIN 51517-3
Operating pressure, static:	15/28/42 L/min – max. 6 bar 58/86 L/min – max. 8 bar
Suction pressure:	max. -0.4 bar
Operating oil temperature:	max. 80 °C
max. viscosity:	100 cSt medium viscosity (see viscosity charts), higher upon request
Ambient temperature:	-15 to 40 °C

Electric motors (others available upon request)

Voltage / frequency:	230 / 400 V - 50 Hz ± 5 % 277 / 480 V - 60 Hz ± 5 %
Thermal stability:	Class of insulation F, utilisation per class B
Colour:	RAL 7031
Protection class:	IP 55
The motors comply with standards IEC 60034, IEC 60072, IEC 60085	

Please also observe the operating manual for the motor!

Basic data BNK ATEX-3GDT3 (at a frequency of 50 Hz)

Part no.*	Cooler type	spec. cooling power kW/K	Cooling power at ETD = 40 K (kW)	max. circulation rate (L/min)	Power output Poles Rated current at 400 V	Weight (kg)	Capacity (l)	Noise emission db(A)**
3602401ATEX3GDT3	BNK 2.4-15-0.75kW	0.07	2.8	15	0.75 kW / 4 / 1.7 A	40	1.3	66
3602402ATEX3GDT3	BNK 2.4-30-0.75kW	0.1	4	28	0.75 kW / 4 / 1.7 A	40	1.3	66
3603401ATEX3GDT3	BNK 3.4-15-0.75kW	0.12	4.8	15	0.75 kW / 4 / 1.7 A	47	1.8	71
3603402ATEX3GDT3	BNK 3.4-30-0.75kW	0.19	7.6	28	0.75 kW / 4 / 1.7 A	47	1.8	71
3604407ATEX3GDT3	BNK 4.4-40-1.5kW	0.27	10.8	42	1.5 kW / 4 / 3.4 A	59	2.3	73
3604404ATEX3GDT3	BNK 4.4-90-2.2kW	0.3	12	86	2.2 kW / 4 / 5 A	77	2.3	73
3605414ATEX3GDT3	BNK 5.4-90-2.2kW	0.44	17.8	86	2.2 kW / 4 / 5 A	86	3.1	79
3606613ATEX3GDT3	BNK 6.6-60-2.2kW	0.52	20.8	58	2.2 kW / 6 / 5.2 A	116	4.1	74
3607414ATEX3GDT3	BNK 7.4-90-3.0kW	0.84	33.6	86	3 kW / 4 / 6.6 A	127	5.4	89

*Cooler models BNK2.4-15 to BNK 4.4-90 operate at 50/60 Hz, BNK 5.4-90 to BNK 7.4-90 at 50 Hz (60 Hz models available upon request).

**DIN EN ISO 3744, Class 3

Calculation example and nomenclature

t_{OE} [°C]	Inlet oil temperature
t_{LE} [°C]	Inlet air temperature
ETD [K]	Temperature differential: $ETD = t_{OE} - t_{LE}$
P_{spez} [kW / K]	specific cooling performance (see performance curves): $P_{spez} = P / ETD$
P [kW]	Cooling performance in kW
Q [l/min]	Oil flow rate
C_{oil} [kJ/kgK]	Specific heat capacity of the oil (approx. 2.0 kJ / kgK)
ζ [kg/dm ³]	Gravity of oil ≈ 0.9 kg/dm ³

Calculation example

Assumptions:

Tank capacity	(V)	approx. 200 L
Start up temperature of oil	(T ₁)	15 °C (≈ 288 K)
Oil heats up in approx. t = 25 min. (1500 s) to	(T ₂)	45 °C (≈ 318 K)
Required oil temperature	(t _{OE})	60 °C
Inlet air temperature	(t _{LE})	30 °C

Calculation:

- Calculating P from the tank warming

$$P = \frac{V \cdot \zeta \cdot c_{Oil} (T_2 - T_1)}{t} = \frac{200 \text{ l} \cdot 0.9 \frac{\text{kg}}{\text{l}} \cdot 2 \frac{\text{kJ}}{\text{kg} \cdot \text{K}} \cdot (318 \text{ K} - 288 \text{ K})}{1500 \text{ s}} = 7.2 \text{ kW}$$

- ETD = $t_{OE} - t_{LE} = 60 \text{ °C} - 30 \text{ °C} = 30 \text{ K}$
- Determining the cooler size: $P_{spez} = P / ETD = 7.2 \text{ kW} / 30 \text{ K} = 0.24 \text{ kW/K}$
- Select a cooler from the basic data with $P_{spez} 0.24 \text{ kW/K}$. There is one option: BNK 3.4 with 30 L pump

Dimensions

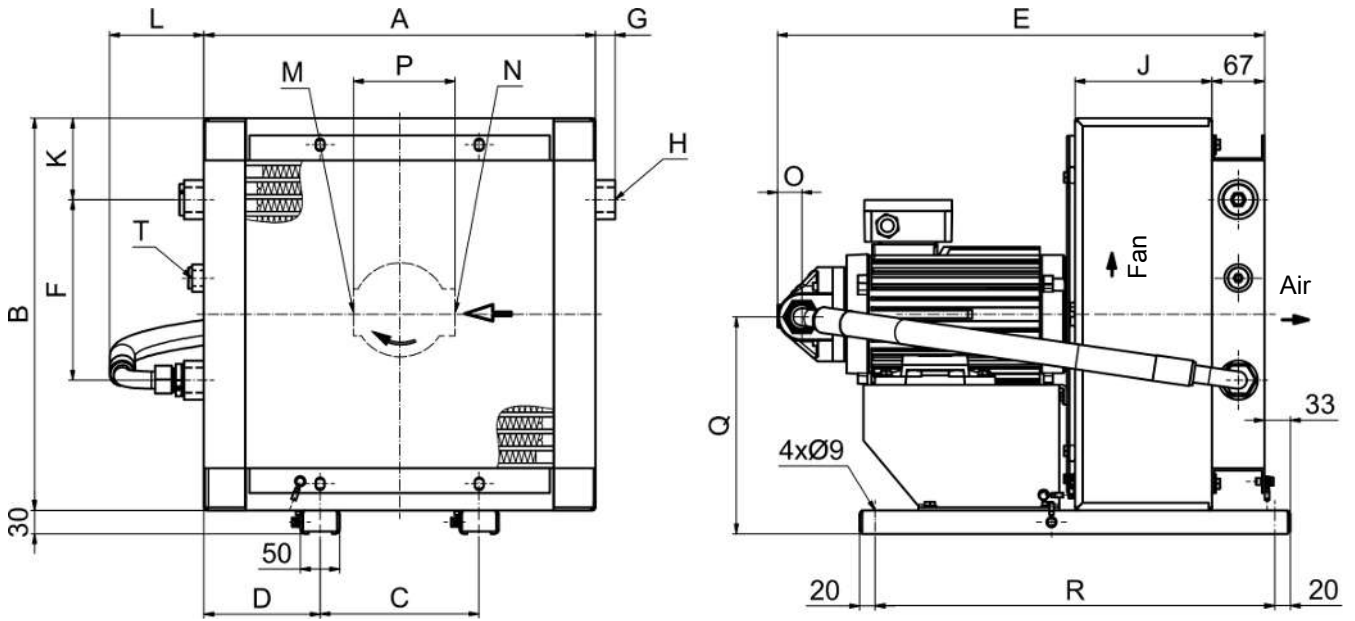

T Connection G 1/2 for temperature switch

Type	A	B	C	D	E	F	G	H	J	K	L	M	N	O	P	Q	R
BNK 2.4-15-0.75kW	370	370	203	83.5	497	-	25	2x G1	125	106	119	G1	G1 1/4	30	130	212	510
BNK 2.4-30-0.75kW	370	370	203	83.5	495	-	25	2x G1	125	106	119	G1	G1 1/4	30	130	212	510
BNK 3.4-15-0.75kW	440	440	203	118.5	523	230	25	3x G1	150	105	119	G1	G1 1/4	30	130	247	510
BNK 3.4-30-0.75kW	440	440	203	118.5	521	230	25	3x G1	150	105	119	G1	G1 1/4	30	130	247	510
BNK 4.4-40-1.5kW	500	500	203	148.5	622	230	25	3x G1	175	104	119	G1	G1 1/4	30	130	277	510
BNK 4.4-90-2.2kW	500	500	203	148.5	749	230	25	3x G1	175	104	135	G1 1/4	G1 1/2	53	135	277	510
BNK 5.4-90-2.2kW	580	580	356	112	774	305	23.5	3x G1	200	100	134	G1 1/4	G1 1/2	53	135	317	510
BNK 6.6-60-2.2kW	700	700	356	172	837	410	9.5	3x G1 1/4	225	110	132	G1 1/4	G1 1/2	53	135	377	610
BNK 7.4-90-3.0kW	700	840	356	172	864	590	9.5	3x G1 1/4	250	91	132	G1 1/4	G1 1/2	53	135	447	610

Functional diagram

Standard version BNK 2

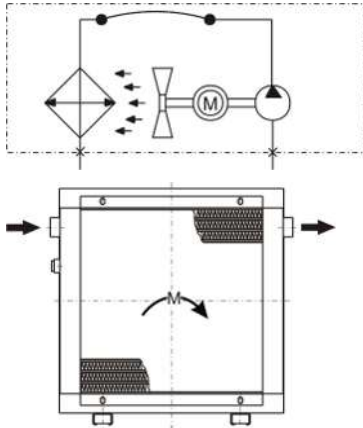

The oil inlet is on the left of the cooling battery. The oil outlet is always on the opposite side.

Standard version BNK 3 to BNK 7

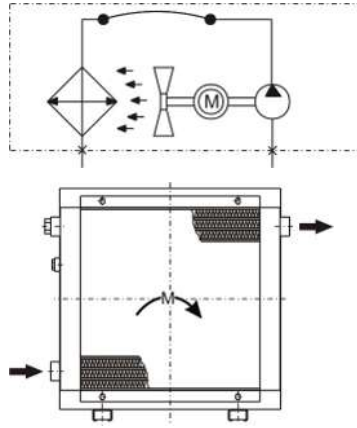

The oil inlet is on the bottom left of the cooling battery. The second connection at the top must be closed. The oil outlet is always on the opposite side.

Internal bypass IB/ITB (BNK 3-7)

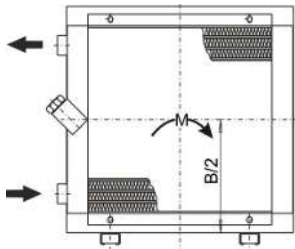

The oil inlet and outlet is always on the same side of the cooling battery. The connection on the opposite side must be closed.

External bypass AB/ATB (BNK 2-7)

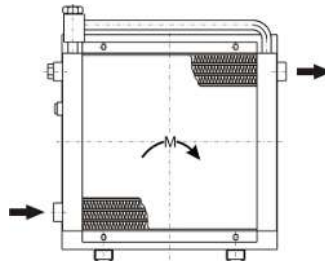

The oil inlet is always at the bottom left of the cooling battery. The second connection must be closed. The oil outlet is always on the opposite side.

With bypass valve

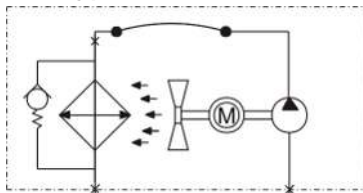

With temperature-dependent bypass valve

